

# RXH/Hi

## INTEGRATED REFRIGERANT CIRCUIT HEAT RECOVERY UNITS



### INTRODUCTION

Any room requires the correct supply of outside air and at the same time the control of the internal thermohygrometric conditions. Through the recovery of energy from the air extracted from the environment, through the use of systems with integrated heat pump technology, an economic way in the installation of energy-efficient power plants is offered, which also ensures the degree of comfort to the occupants, both in summer and winter and without added costs in the management of primary air.

For buildings that require air exchange and are not equipped with dedicated air conditioning systems, the installation of these units allows the introduction of primary air at a controlled temperature without disturbing the internal conditions in the occupied spaces.

It is therefore not necessary to use additional systems to heat or cool the incoming primary air. Moreover, these units allow to guarantee a support to the air conditioning system in the intermediate seasons by exploiting the free-cooling or free-heating periods. If installed on existing buildings, they guarantee the energy upgrading of the system through the management of the air exchange without additional charges. On new installations, on the other hand, the air exchange is completely carried out allowing to reduce the size of the main air conditioning system.

In the intermediate seasons the building will benefit from the free or partial cooling generated by these units, which during the partial load phases allow the main system to operate with higher efficiencies.

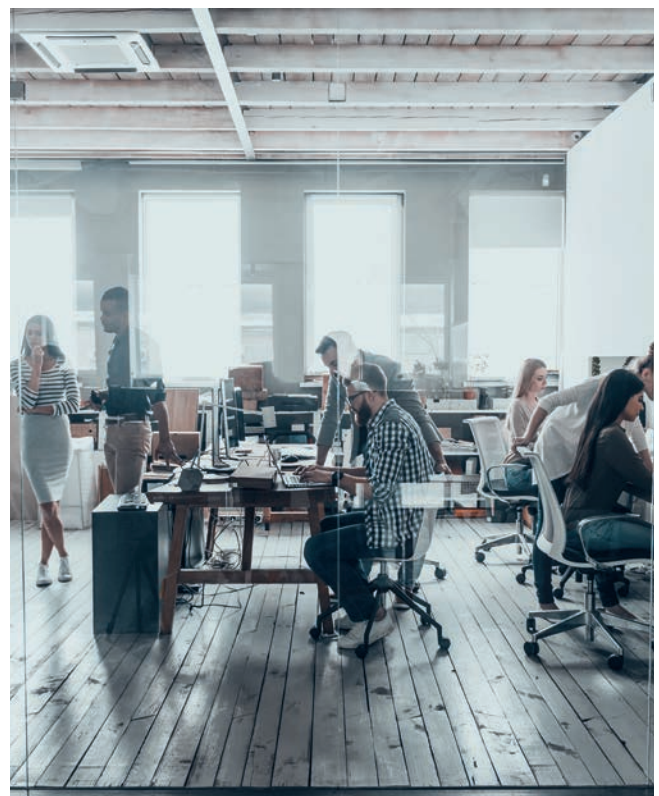

## OPERATING MODE

### • HEATING

The return air, after crossing the crossflow heat recovery, feeds the heat pump source exchanger that acts as an evaporator. Through the steam compression refrigeration cycle, the fresh air, leaving first recovery stage, is heated by the heat pump user exchanger, which acts as a condenser.

The modulation of the thermal capacity, obtained by means of the compressor, will allow the temperature of the supply air to be precisely controlled. During heating operation, the evaporator of the heat pump, may be subject to the formation of surface frost resulting in loss of efficiency.

To prevent this from happening, the unit provides for the controlled management of a defrosting cycle obtained by reversing the refrigeration cycle.

During this phase, the return fans are stopped and the compressors are forced at maximum speed.

Through the other additional heating resources present in the unit, water heating coils, electric heaters or other refrigeration compressors temporarily not working, the temperature of the supply air is maintained at an appropriate value so as not to disturb the internal environment.

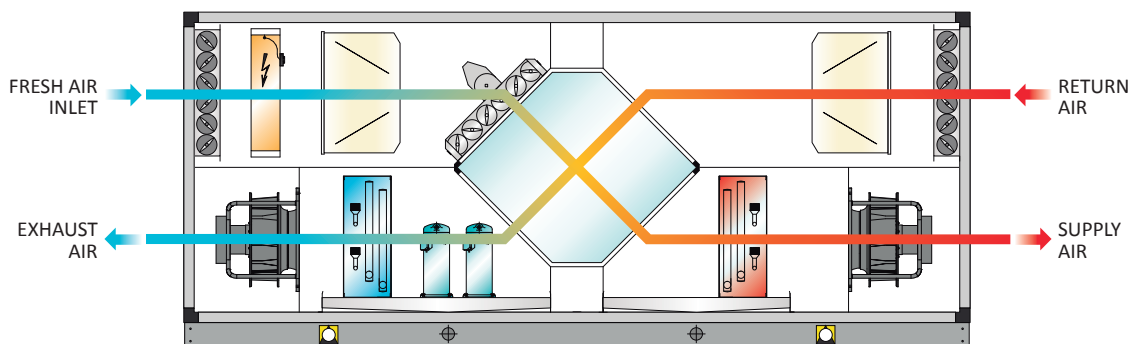

### • COOLING

The return air, after crossing the cross-flow heat recovery, feeds the heat pump source exchanger, which acts as a condenser.

The external air, after crossing the cross-flow heat recovery, is cooled by the heat pump user exchanger, which acts as an evaporator.

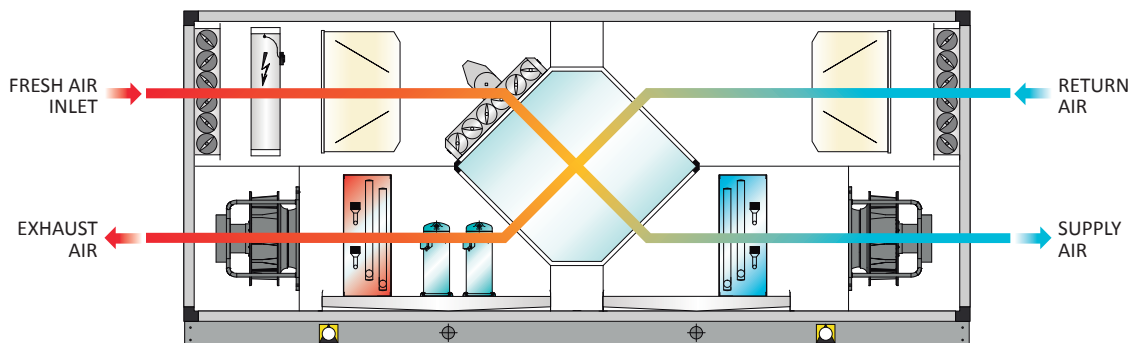

### • FREE-COOLING

When the outdoor temperature is lower than the indoor temperature of the room to be air conditioned, if this

requires cooling, the units operate in free-cooling mode and all stages of integrated heat recovery are disabled.

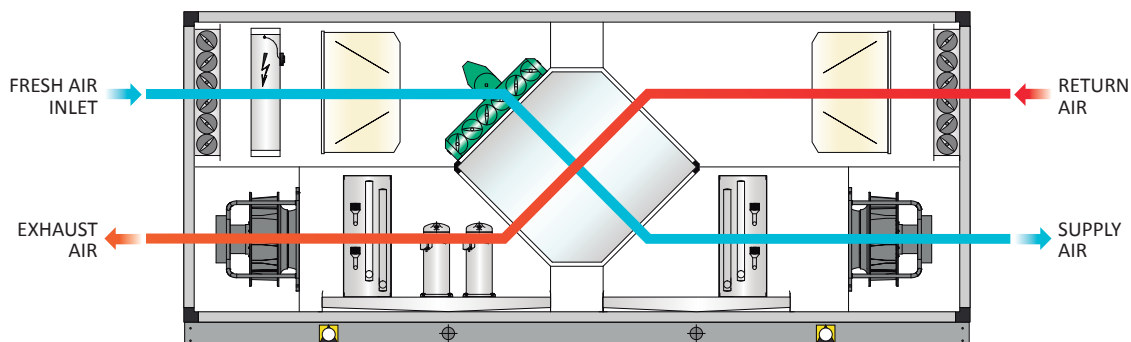

## MAIN CHARACTERISTICS

### 1 | STRUCTURE AND PANELS

The structure of the units can be realized in two versions:

#### VERSION 1:

Profiles 50 x 50 mm in self-supporting extruded anodized aluminium, with mechanical strength requirements in accordance with EN 1886: D1 (M). 50 mm thick double wall sandwich type paneling with exterior in pre-painted RAL 9010 galvanized sheet steel and interior in hot-dip galvanized sheet steel with interposed insulation made of polyurethane foam with a density of 40 kg/m<sup>3</sup>.

This structure has a seal class L1 while the thermal transmittance and the thermal bridge characteristic is class T3/TB4 according to EN1886.

#### VERSION 2:

Thermal break profiles 60 x 60 mm in self-supporting extruded anodized aluminium, with mechanical strength requirements in accordance with EN 1886: D1 (M). 63 mm thermal break sandwich-type double-walled sandwich-type panels with exterior in pre-painted RAL 9010 galvanized sheet steel and interior in hot-dip galvanized sheet steel with interposed insulation made of polyurethane foam with a density of 40 kg/m<sup>3</sup>.

This structure has a seal class L1 while the thermal transmittance and the thermal bridge characteristic is class T2/TB2 according to EN1886.

Safety microswitches are applied to the inspection doors to allow internal access to the various compartments of the unit only when the unit is completely switched off.

The main access and inspection panels consist of inspection doors with perimeter hinges made of non-corrosive polyamide and handles.

All units can be supplied in both monobloc and modular sections for on-site assembly when required.

### 2 | AIR FILTERS

Panel filters class ePM<sub>10</sub> 60% (M5) on return air and bag filters class ePM<sub>1</sub> 55% (F7) for fresh air section in accordance with international norms.

### 3 | HEAT RECOVERY (1st stage of recovery)

The units are equipped with a counter-flow heat exchanger in aluminium (painted on request) used in cooling/heating mode with efficiencies higher than 80%. Through the integrated control system it is possible to manage the defrosting of the heat recovery by activating different stages of electrical resistances (pre-heaters), or by activating the recirculation damper. The heat recovery is also equipped with an additional by-pass damper for the management of the free-cooling and free-heating mode. The heat exchanger participates to the **Eurovent Certification** program and it is sized according to the **ECO Design** specification.

### 4 | THERMODYNAMIC RECOVERY (2nd stage of recovery)

The thermodynamic and energy efficiency of the unit is further improved thanks to a second phase of indirect recovery, obtained through a compression system of the refrigeration circuit in heat pump.

### 5 | FANS

High efficiency plug-fans with built-in brushless EC motor and an integrated electronic control system, thus ensuring that the correct functioning of the unit is maintained, with consequent savings in the energy absorbed. Through a reliable pressure sensor installed it is possible to select and control the air flow through a constant flow control, or at a fixed useful static pressure. On request, it is possible to supply the fan sections with portholes and low consumption internal lighting elements supplied directly from the electrical panel on board the machine or from an independent external source.

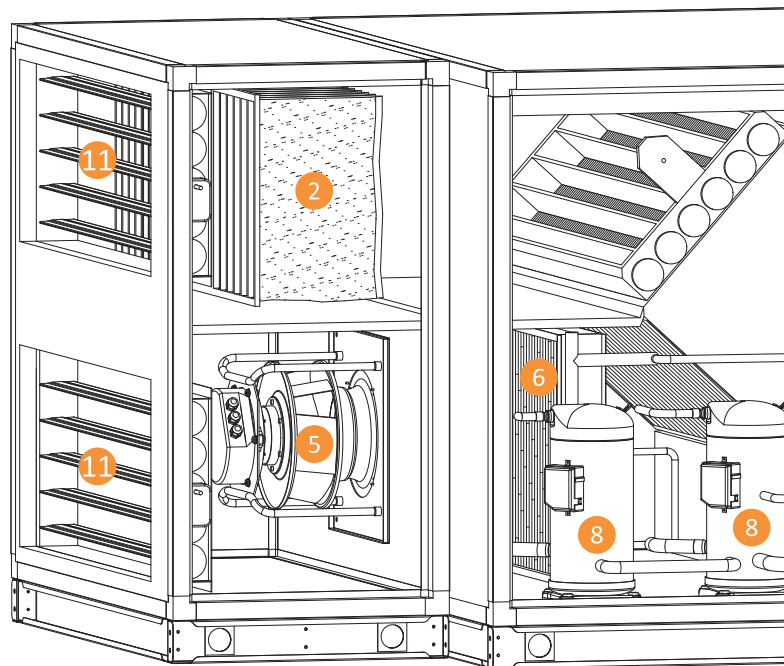

### 6 | FINNED PACK HEAT EXCHANGERS

The evaporative-condensing coils positioned inside the supply and exhaust air sections consist of internally and mechanically expanded striped copper tubes and hydrophilic painted aluminium fins, that guarantees rapid drainage of condensation and dragging effects both during dehumidification and defrosting, in addition to increase the resistance to corrosion, due to acids or pollutants contained in the treated air. The direct expansion coil is equipped with an electronic expansion valve managed by the control integrated in the unit and operated in such a way as to guarantee the correct overheating of the refrigerant that reaches the refrigeration compressor in the various operating situations. The stainless steel condensate drain pan with ductable outlet complies with ASHRAE 62-89 self-draining standards.

## CONTROLS

### 7 | CONTROLS

The unit is complete with controls by means of a microprocessor electronic board with dedicated software and external LCD display as user interface. Through the external or remote LCD display it is possible to set all the working set-points of the unit and display the operating status and any alarm conditions present.

Through the values acquired by the room temperature probe and the supply air, the thermoregulation will be managed by activating the compressors with reference to the winter and summer set-points. The unit can manage the automatic change of cooling or room heating modes, free-cooling and free-heating conditions by comparing them with the outside air temperature.

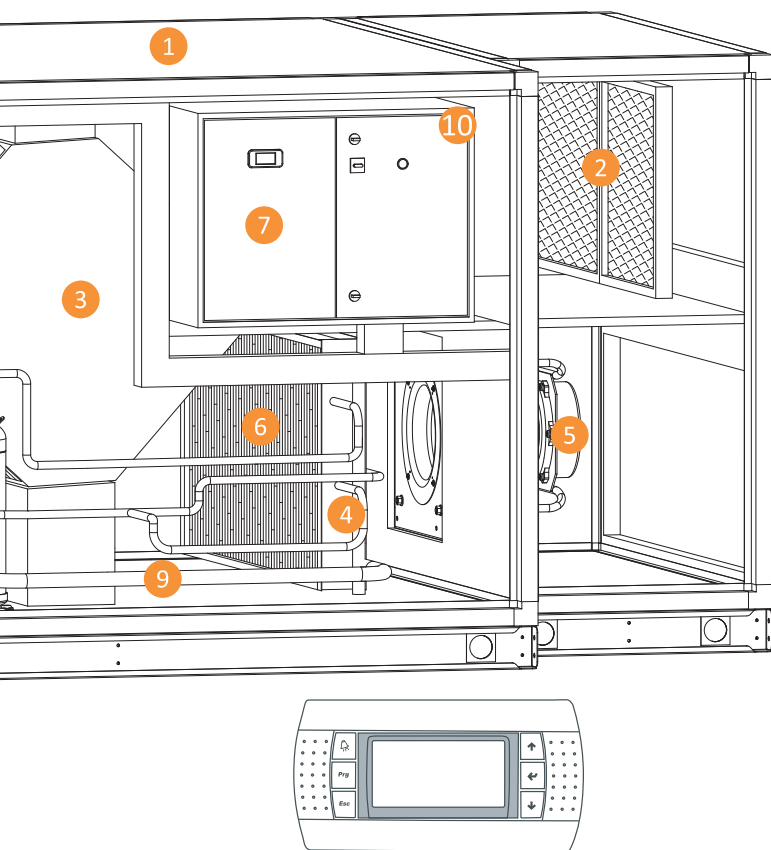

The thermal capacity delivered by the heat pump unit will be continuously modulated through the speed variation of the DC brushless rotary or scroll refrigeration compressor.

This variable depends mainly on the value of the supply air temperature with reference to the external air conditions. This characteristic allows the operation at partial loads with a much higher energy saving compared to a traditional system equipped with ON/OFF compressors.

### 8 | COMPRESSORS

The main refrigerant circuit is equipped with hermetic Twin or Scroll rotary compressors with a single brushless DC motor suitable to be managed by an inverter, for a continuous control of the refrigeration capacity. The compressor is complete with thermal protection, crankcase heating, low and high pressure switches and vibration dampers suitable for isolating vibrations. The additional cooling circuits are supplied with hermetic rotary compressors and ON/OFF scrolls.

These compressors allow you to increase the cooling or heating capacity by being used as boosters with inverter, which will allow you to precisely adjust the capacity with respect to the required load.

On request, the compressors can be equipped with a soundproofing hood to lower the noise level emitted by the unit.

### 9 | REFRIGERATION CIRCUIT

The refrigerant circuit is of direct expansion type loaded with refrigerant R410a. Each refrigerant circuit is tested at the factory with reference to both its tightness (pressure test) and its functionality. The main components are: evaporative-condensing finned pack heat exchangers, electronic expansion devices, solid cartridge acid filters, high and low refrigerant pressure switches, receiver and suction liquid separator, liquid/humidity indicator light, cycle reversal valve, non-return valves, high pressure safety valves.

The circuit is complete with a combined hot gas injection and fresh air by-pass defrosting system that operate both on the plate heat recovery and the source heat exchanger.

### 10 | ELECTRIC BOX

It is housed in a dedicated IP54 technical compartment, equipped with a double door to ensure both internal and external installation of the unit.

The electrical panel is manufactured according to IEC 204-1 / EN 60204-1 standards and complete with door block disconnecter, CE isolation transformer and internal thermostated anti-condensation resistors for outdoor units. All motors and auxiliary circuits are protected against overload and short circuit by fuses and/or circuit breakers.

### 11 | AIR DAMPERS

All adjustment dampers are made of aluminium with a low pressure drop wing profile and opposing wings.

Each damper is equipped with an electric actuator already assembled and directly managed by the electronic control on board.

## SAFETY AND CONTROL DEVICES

---

- **Supply air temperature probe**

Passive sensor type NTC 10k $\Omega$ . Positioned on the supply air side, downstream of the heating/cooling units, it is used to monitor the temperature of the air supplied to the room. It is installed in combination with the temperature control accessories (water coils or post-heating electric resistance). Through this probe it is also possible to control eventual air delivery temperatures in the environment that are too cold in summer or too hot in winter.

- **Return air temperature probe**

Passive sensor type NTC 10k $\Omega$ . Positioned on the room air intake and upstream of the filtering section, its purpose is to monitor the temperature of the air extracted from the room to be treated. Always present in all units, it is used as a control probe of the room temperature set and for the management of the summer free-cooling function.

- **Outdoor air temperature probe (fresh air)**

Passive sensor type NTC 10k $\Omega$ . Positioned on the fresh air intake and upstream of the filtering section, it is used for monitoring the temperature of the fresh air entering the heat recovery unit. Always present in all units, it is used in combination with the room air intake temperature probe to manage the summer free-cooling function.

- **Exhaust air temperature probe**

Passive sensor type NTC 10k $\Omega$ . Positioned on the air outlet and downstream of the plate heat exchanger, it monitors the temperature of the air exhausted from the unit. It is installed in combination with the defrosting kit with the function of controlling the exhaust temperature of the plate heat exchanger in order to avoid freezing of the same during the winter operation of the unit.

- **Source exchanger defrost kit**

The source heat exchanger defrost kit is composed of a pressure transducer and a cycle inversion valve, directly managed by the microprocessor control. In case, in heating mode, the conditions downstream the plate heat exchanger should fall below the ice formation threshold, the defrost system would activate, which would invert the refrigerant gas flow and send hot gas to the heat exchanger to defrost.

As soon as the conditions downstream the heat exchanger would allow, the heating operating mode would be reset.

- **Differential pressure switch**

This component is used to monitor the clogging status of the air filters. There are two pressure switches for each unit, one installed on the fresh air filter section and one located on the room return air filter section. If one of the filters has a pressure difference greater than the recommended limit, an alarm is displayed on the user interface.

- **Differential pressure transducer**

Active type transducer with 4-20mA output signal. It is located inside the control board and connected to the supply fan pressure sockets. The task is to maintain the air volume as constant at the variation of the internal pressure drop (dirtying of the filters).

- **Low pressure switch**

The low pressure switch stops the unit when the suction gas pressure is lower than the default value. The reset is automatic and it takes place when the gas pressure is superior to the set differential value. The pressure switch is set to allow for a maximum of 3 automatic resets per hour.

- **High pressure switch**

The high pressure switch stops the unit when the supply gas pressure is above default value. The reset is automatic and it takes place when the gas pressure is below the set differential value. The pressure switch is set to allow for a maximum of 3 automatic resets per hour.

- **Compressor discharge temperature sensor**

Passive NTC-type sensor mounted on the compressor discharge side, used to limit the discharge gas temperature.

## TECHNICAL DATA

MODEL		011	021	031	041	061	081	101
Nominal airflow rate	m <sup>3</sup> /h	1000	2000	3000	4500	6000	8000	10000
Thermal efficiency recovery in cooling mode <sup>(1)</sup>	%	77,90	78,40	77,90	77,90	78,10	78,50	74,90
Total unit cooling capacity <sup>(1)</sup>	kW	6,59	14,75	21,98	33,82	43,70	54,24	66,46
Total EER of unit <sup>(1)</sup>	W/W	6,79	5,57	5,97	5,98	5,46	6,09	5,63
Electrical power absorbed in cooling mode <sup>(1)</sup>	kW	1,63	3,88	5,62	8,67	11,93	14,11	17,79
Heating recovery thermal efficiency <sup>(2)</sup>	%	92,90	94,20	94,40	94,60	94,70	95,30	89,10
Total thermal power of unit <sup>(2)</sup>	kW	12,73	24,74	40,31	56,69	77,91	98,73	122,72
Total COP of unit <sup>(2)</sup>	W/W	12,60	13,98	11,10	13,03	11,63	12,36	10,31
Electrical power absorbed in heating <sup>(2)</sup>	kW	1,67	2,95	5,52	7,26	10,54	13,00	17,68
Supply fan available static pressure	Pa	250	250	250	250	250	250	250
Return fan available static pressure	Pa	200	200	200	200	200	200	200
N° of refrigerant circuits	n°	1	1	1	1	1	1	1
Type of refrigerant		R410A						
Number of compressors: Inverter	n°	1	1	1	1	1	1	1
Max. electricity absorbed by the unit	A	26,90	26,80	34,00	44,40	53,50	60,20	64,20
Power supply	V/ph/Hz	400 V +- 10% / 3 / 50 + N + $\underline{\underline{\text{PE}}}$						
Type of filters for fresh air section		F7	F7	F7	F7	F7	F7	F7
Type of filters for return air section		M5	M5	M5	M5	M5	M5	M5
SFP factor filters	W/(l/s)	2,09	1,96	2,15	2,18	2,18	2,19	1,99
Supply sound power level <sup>(3)</sup>	dB(A)	80	80	80	84	84	85	85
Return sound power level <sup>(3)</sup>	dB(A)	66	65	68	69	73	73	72
Sound pressure level in scale A (ISO EN 3744) <sup>(4)</sup>	dB(A)	57	56	54	59	59	60	60

MODEL		062	082	102	132	172	242
Nominal airflow rate	m <sup>3</sup> /h	6000	8000	10000	13000	17000	24000
Thermal efficiency recovery in cooling mode <sup>(1)</sup>	%	78,10	78,50	74,90	75,10	75,30	74,90
Total unit cooling capacity <sup>(1)</sup>	kW	43,80	55,00	67,49	93,77	116,77	149,75
Total EER of unit <sup>(1)</sup>	W/W	5,41	5,92	5,62	5,32	5,36	5,76
Electrical power absorbed in cooling mode <sup>(1)</sup>	kW	12,03	14,50	17,99	25,87	32,36	42,08
Heating recovery thermal efficiency <sup>(2)</sup>	%	94,70	95,30	89,10	89,70	90,20	89,80
Total thermal power of unit <sup>(2)</sup>	kW	78,06	100,25	126,22	156,99	204,52	265,78
Total COP of unit <sup>(2)</sup>	W/W	11,92	12,69	10,40	11,97	11,95	15,18
Electrical power absorbed in heating <sup>(2)</sup>	kW	10,39	12,91	17,92	21,17	27,54	32,87
Supply fan available static pressure	Pa	250	250	250	250	250	250
Return fan available static pressure	Pa	200	200	200	200	200	200
N° of refrigerant circuits	n°	2	2	2	2	2	2
Type of refrigerant		R410A					
Number of compressors: Inverter + On/Off	n°	1 + 1	1 + 1	1 + 1	1 + 2	1 + 2	1 + 2
Max. electricity absorbed by the unit	A	51,40	53,40	73,60	84,70	99,70	103,70
Power supply	V/ph/Hz	400 V +- 10% / 3 / 50 + N + $\underline{\underline{\text{PE}}}$					
Type of filters for fresh air section		F7	F7	F7	F7	F7	F7
Type of filters for return air section		M5	M5	M5	M5	M5	M5
SFP factor filters	W/(l/s)	2,18	2,19	1,99	2,13	2,09	2,26
Supply sound power level <sup>(3)</sup>	dB(A)	84	85	85	92	94	96
Return sound power level <sup>(3)</sup>	dB(A)	73	73	72	76	77	85
Sound pressure level in scale A (ISO EN 3744) <sup>(4)</sup>	dB(A)	59	60	60	61	63	63

<sup>(1)</sup> fresh air inlet +35 °C / 40% RH, return air +26 °C / 50% RH

<sup>(2)</sup> fresh air inlet -10 °C / 90% RH, return air +20 °C / 50% RH

<sup>(3)</sup> sound power level calculated in accordance with EN 3744

<sup>(4)</sup> sound pressure level measured at 1 m free field distance, ducted unit in accordance with EN 3744

## ACCESSORIES

MODEL	011	021	031	041	061	062	081	082	101	102	132	172	242
Supply and return EC fans	■	■	■	■	■	■	■	■	■	■	■	■	■
Counter-flow plate heat recovery	■	■	■	■	■	■	■	■	■	■	■	■	■
ePM <sub>10</sub> 60% (M5) return filter / ePM <sub>1</sub> 55% (F7) supply filter	■	■	■	■	■	■	■	■	■	■	■	■	■
Inverter compressor	■	■	■	■	■	■	■	■	■	■	■	■	■
Filters differential pressure switches	■	■	■	■	■	■	■	■	■	■	■	■	■
Fans differential pressure transducers	■	■	■	■	■	■	■	■	■	■	■	■	■
100% by-pass damper with actuator	■	■	■	■	■	■	■	■	■	■	■	■	■
Microprocessor control system with display	■	■	■	■	■	■	■	■	■	■	■	■	■
Integrated defrost system	■	■	■	■	■	■	■	■	■	■	■	■	■
RS-485 serial port Modbus protocol	■	■	■	■	■	■	■	■	■	■	■	■	■
50 mm frame or 60 mm thermal break frame	□	□	□	□	□	□	□	□	□	□	□	□	□
40 kg/m <sup>3</sup> polyurethane panels thermal insulation	□	□	□	□	□	□	□	□	□	□	□	□	□
90 kg/m <sup>3</sup> mineral wool panels thermal insulation	□	□	□	□	□	□	□	□	□	□	□	□	□
Filters ePM <sub>1</sub> 55% (F7) return and/or ePM <sub>1</sub> 80% (F9) supply/return	□	□	□	□	□	□	□	□	□	□	□	□	□
Pre-filters ePM <sub>10</sub> 50% (G4) on supply/return	□	□	□	□	□	□	□	□	□	□	□	□	□
Return grease ISO Coarse 40% (G2) filter	□	□	□	□	□	□	□	□	□	□	□	□	□
Electric frost coil protection	□	□	□	□	□	□	□	□	□	□	□	□	□
Electric heating coil <sup>(1)</sup>	□	□	□	□	□	□	□	□	□	□	□	□	□
Hot water / cold water / direct expansion coil <sup>(1)</sup>	□	□	□	□	□	□	□	□	□	□	□	□	□
3 way modulating valve <sup>(1)</sup>	□	□	□	□	□	□	□	□	□	□	□	□	□
Circular duct flanges (4 pcs)	□	□	□	□	□	□	□	□	□	□	□	□	□
Exhaust/Fresh air damper	□	□	□	□	□	□	□	□	□	□	□	□	□
ON/OFF damper actuator	□	□	□	□	□	□	□	□	□	□	□	□	□
Sound attenuator <sup>(1)</sup>	□	□	□	□	□	□	□	□	□	□	□	□	□
Roof for outdoor installation	□	□	□	□	□	□	□	□	□	□	□	□	□
45° hoods with bird trap (2 pcs)	□	□	□	□	□	□	□	□	□	□	□	□	□
Remote control panel <sup>(2)</sup>	□	□	□	□	□	□	□	□	□	□	□	□	□

<sup>(1)</sup> mounted in a separated box

■ Standard □ Optional - Not available

<sup>(2)</sup> supplied loose

## OPERATING LIMITS

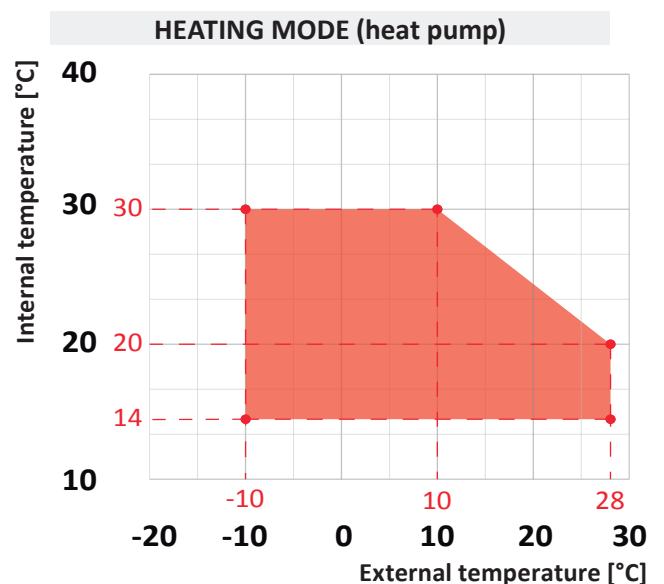
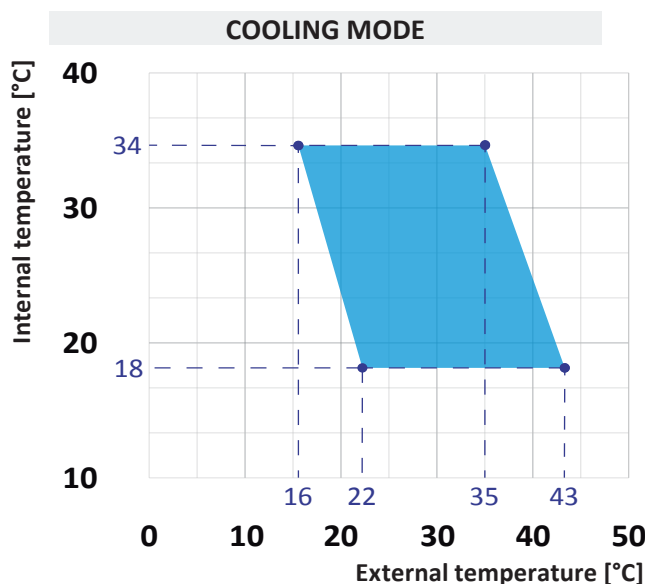

# DIMENSIONAL DRAWING

CONFIGURATION H1

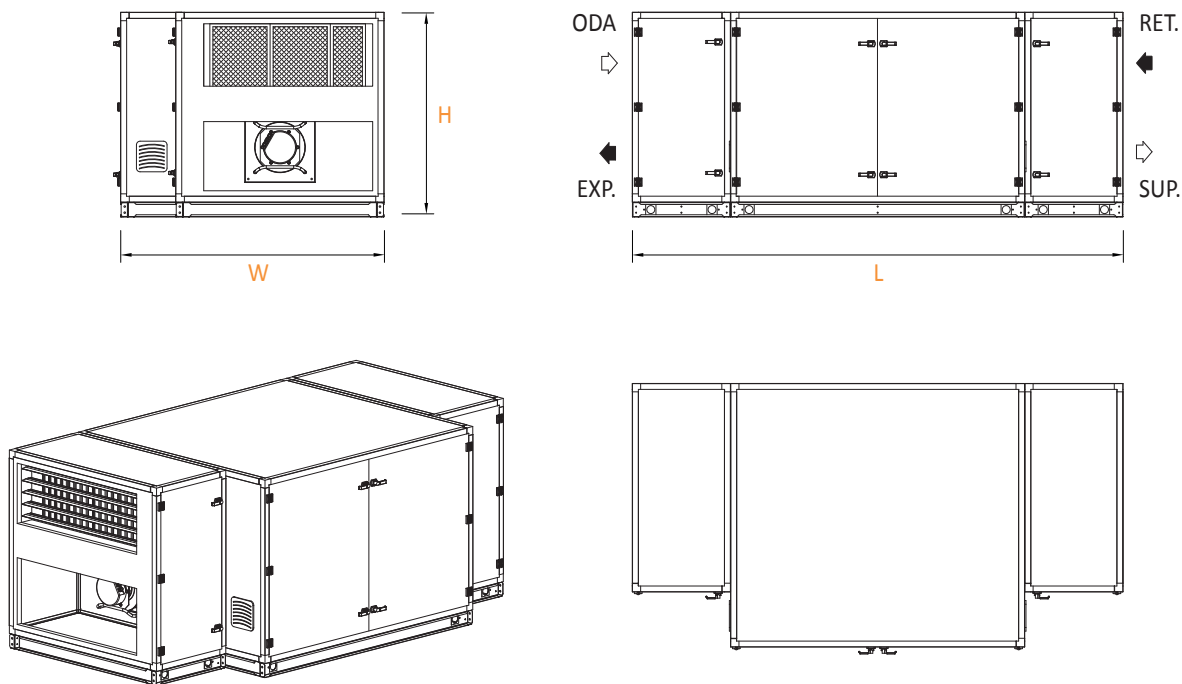

CONFIGURATION H2

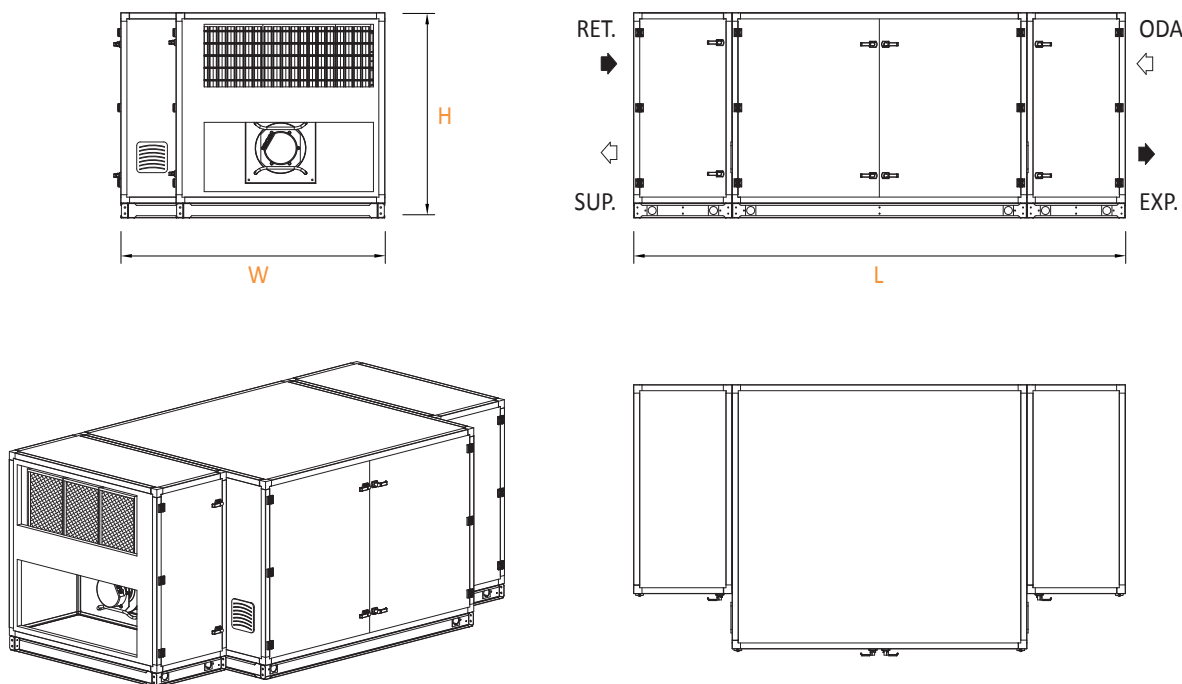

## DIMENSIONS AND WEIGHTS

MODEL	011	021	031	041	061	062	081	082	101	102	132	172	242
<b>L</b> (mm)	2860	2900	3250	3650	3650	3650	3900	3900	4000	4000	4360	4900	5300
<b>W</b> (mm)	1150	1350	1500	1650	1900	1900	2150	2150	2250	2250	2280	2380	2380
<b>H</b> (mm)	1020	1270	1300	1550	1700	1700	1700	1700	1820	1820	2220	2550	2750
<b>Weight</b> (kg)	319	464	581	714	929	929	1043	1043	1160	1160	1375	1706	1932

Dimensions and weights referred to the standard configuration